

FRM-1 Relay Control Module

SPECIFICATIONS

Normal Operating Voltage:	15 to 32 VDC
Maximum Current Draw:	6.5 mA (LED on)
Average Operating Current:	230µA direct poll; 255µA group poll
EOL Resistance:	Not used
Temperature Range:	32°F to 120°F (0°C to 49°C)
Humidity:	10% to 93% Non-condensing
Dimensions:	4.675" H x 4.275" W x 1.4" D (Mounts to a 4" square by 2 1/8" deep box.)
Accessories:	SMB500 Electrical Box; CB500 Barrier

RELAY CONTACT RATINGS:

CURRENT RATING	MAXIMUM VOLTAGE	LOAD DESCRIPTION	APPLICATION
2 A	25 VAC	PF = 0.35	Non-coded
3 A	30 VDC	Resistive	Non-coded
2 A	30 VDC	Resistive	Coded
0.46 A	30 VDC	(L/R = 20ms)	Non-coded
0.7 A	70.7 VAC	PF = 0.35	Non-coded
0.9 A	125 VDC	Resistive	Non-coded
0.5 A	125 VAC	PF = 0.75	Non-coded
0.3 A	125 VAC	PF = 0.35	Non-coded

BEFORE INSTALLING

This information is included as a quick reference installation guide. Refer to the appropriate Notifier control panel installation manual for detailed system information. If the modules will be installed in an existing operational system, inform the operator and local authority that the system will be temporarily out of service. Disconnect power to the control panel before installing the modules.

NOTICE: This manual should be left with the owner/user of this equipment.

GENERAL DESCRIPTION

The FRM-1 Relay Control Module is intended for use in intelligent, two-wire systems where the individual address of each module is selected using the built-in rotary switches. It allows a compatible control panel to switch discrete contacts by code command. The relay contains two isolated sets of Form-C contacts, which operate as a DPDT switch and are rated in accordance with the table in the manual. Circuit connections to the relay contacts are not supervised by the module. The module also has a panel controlled LED indicator. This module can be used to replace a CMX-2 module that has been configured for Form-C operation.

COMPATIBILITY REQUIREMENTS

To ensure proper operation, this module shall be connected to a compatible Notifier system control panel (list available from Notifier).

FIGURE 1. CONTROLS AND INDICATORS:

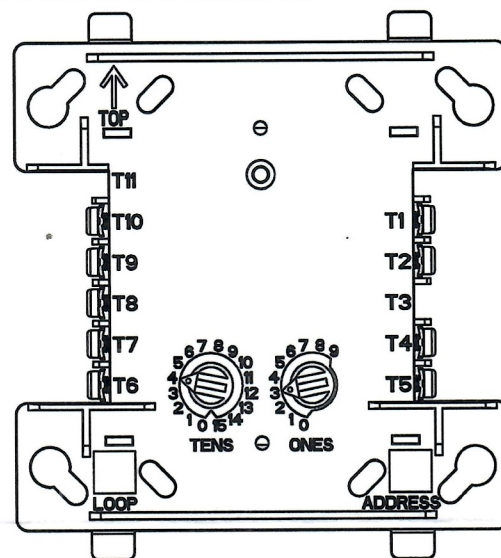

C1071-00

MOUNTING

The FRM-1 mounts directly to 4-inch square electrical boxes (see Figure 2A). The box must have a minimum depth of 2 1/8 inches. Surface mounted electrical boxes (SMB500) are available from Notifier. The module can also mount to the DNR(W) duct housing.

FIGURE 2A. MODULE MOUNTING WITH BARRIER:

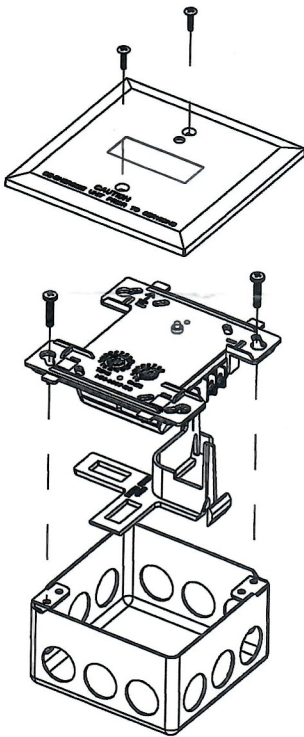
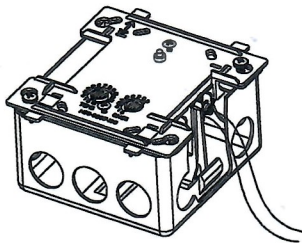

FIGURE 2B:



WIRING

NOTE: All wiring must conform to applicable local codes, ordinances, and regulations. When using control modules in nonpower limited applications, the CB500 Module Barrier must be used to meet UL requirements for the separation of power-limited and nonpower-limited terminals and wiring. The barrier must be inserted into a 4" x 4" x 2 1/8" junction box, and the control module must be placed into the barrier and attached to the junction box (Figure 2A). The power-limited wiring must be placed into the isolated quadrant of the module barrier (Figure 2B).

1. Install module wiring in accordance with the job drawings and appropriate wiring diagrams.
2. Set the address on the module per job drawings.
3. Secure module to electrical box (supplied by installer), see Figure 2A.

Wire should be stripped to the appropriate length (recommended strip length is 1/4" to 3/8"). Exposed conductor should be secured under the clamping plate and should not protrude beyond the terminal block area. Caution: Do not loop wire under terminals. Break wire run to provide supervision of connections.

C1070-00

WARNING

All relay switch contacts are shipped in the standby state (open) state, but may have transferred to the activated (closed) state during shipping. To ensure that the switch contacts are in their correct state, modules must be made to communicate with the panel before connecting circuits controlled by the module.

FIGURE 3. RELAY MODULE WIRING DIAGRAM:

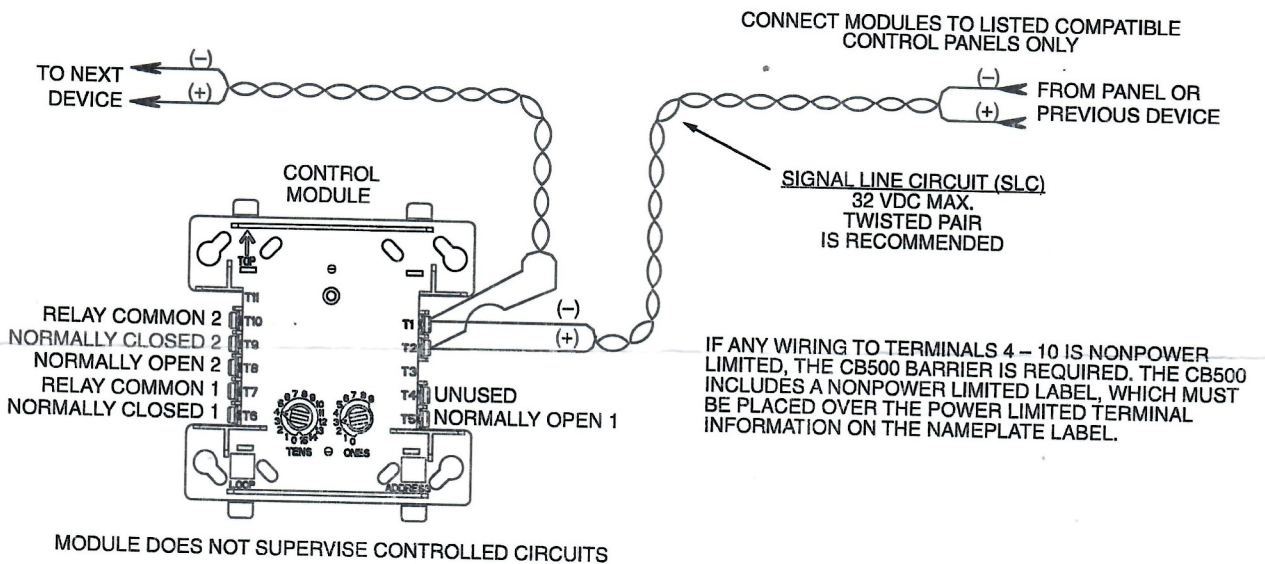

*NOTE: ANY FAULT IN THE POWER SUPPLY IS LIMITED TO THAT ZONE AND DOES NOT RESULT IN A FAULT IN A SEPARATE ZONE.